

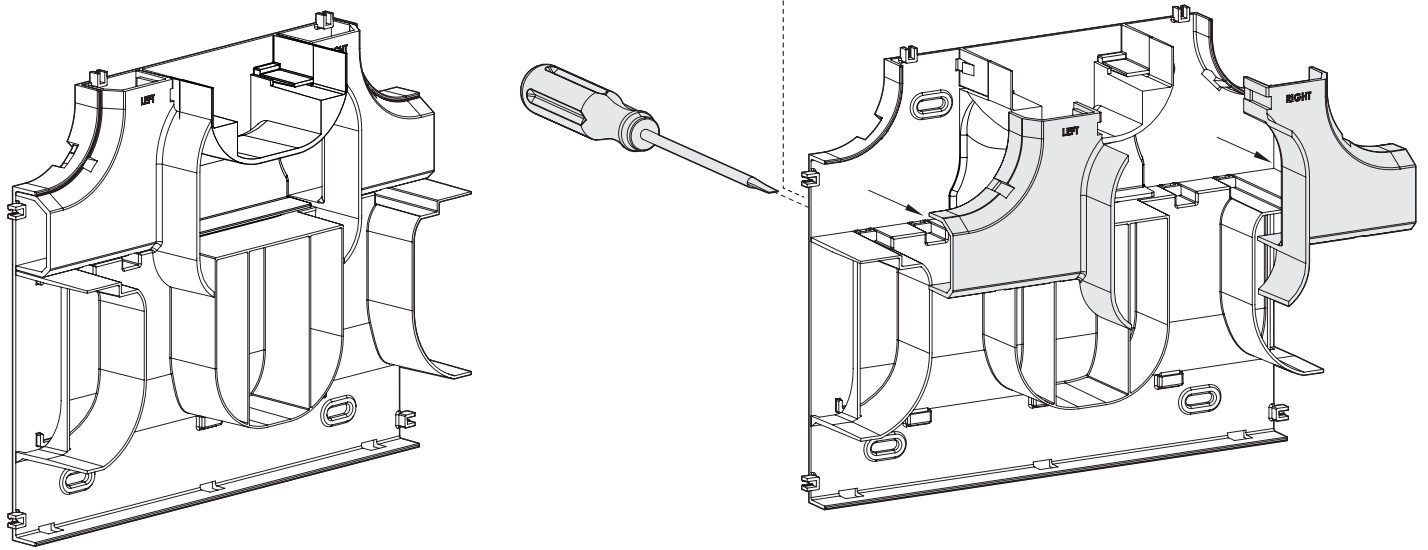

FALCON TRUNKING
Systems Limited

**MERLIN THREE COMPARTMENT DADO PERIMETER TRUNKING FLAT TEE INSTALLATION INSTRUCTIONS
(MERFT/34)**

Installation of this product should only be undertaken by a suitably qualified and/or competent person



1. Component is supplied assembled. Prior to installation 'left' and 'right' bridging pieces will need to be removed to allow the fixing of the backplate to the building fabric. A small flat head screw driver will be required for this purpose.

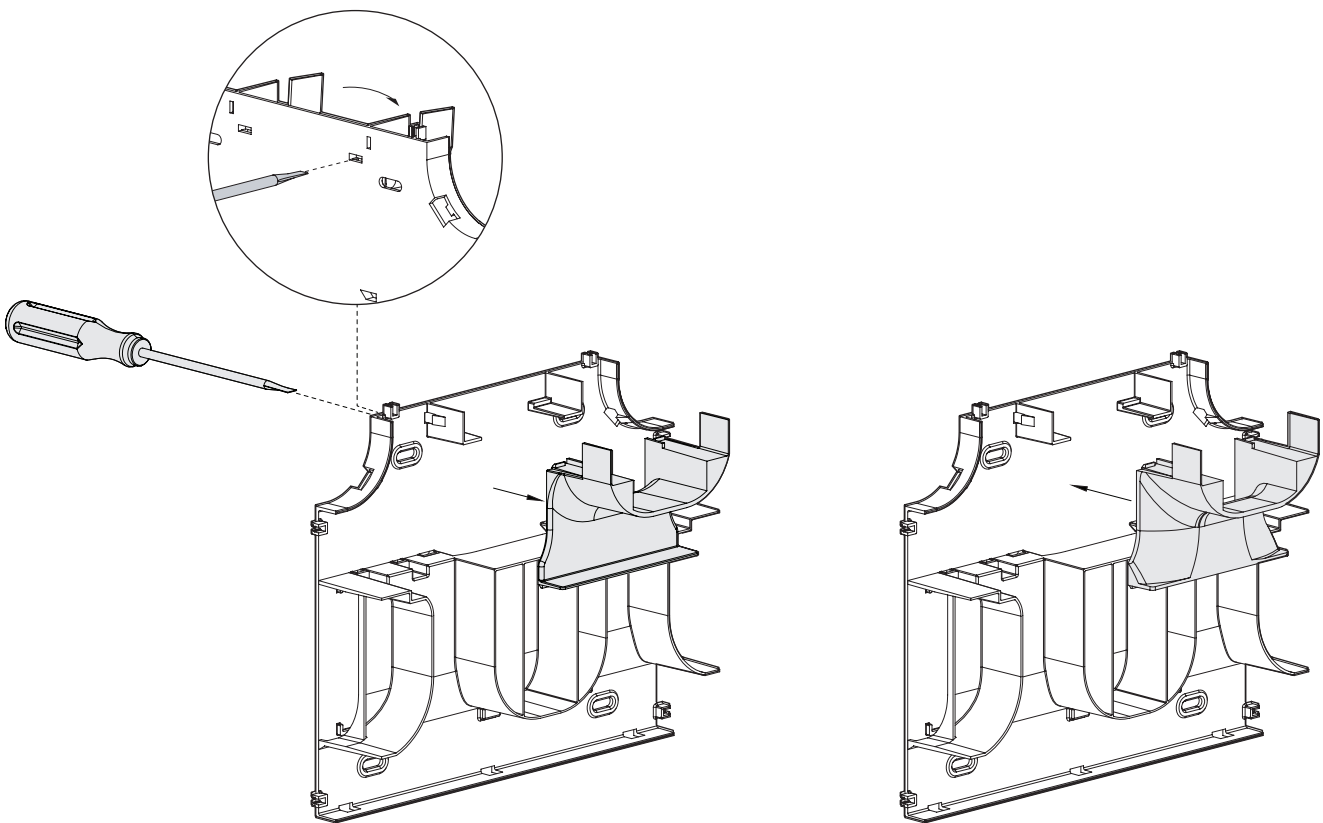

2. Component is supplied formatted with the centre compartment in the 'closed' position to facilitate cables being run in the outermost compartments only. If access to the central compartments is required remove the Centre Compartment Closure (MERFT/CCC) installed and replace with the Centre Compartment Bridge (MERFT/CCF) provided. It is possible to locate this component into position after the cables have been laid in if required.

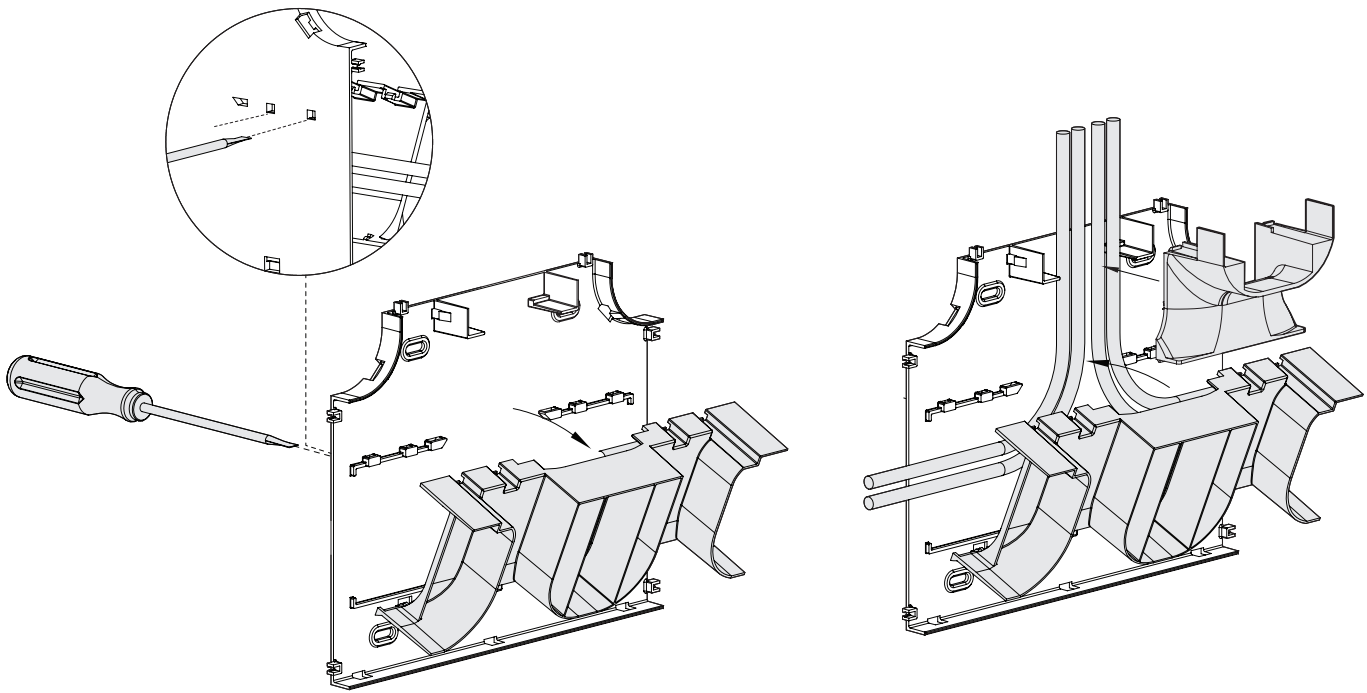

3. Centre Compartment Tunnel (MERFT/CCT) is supplied clipped into position. Should cables within the centre compartment require 'laying in' rather than 'drawing in' it can be removed with the use of a small flat head screwdriver.

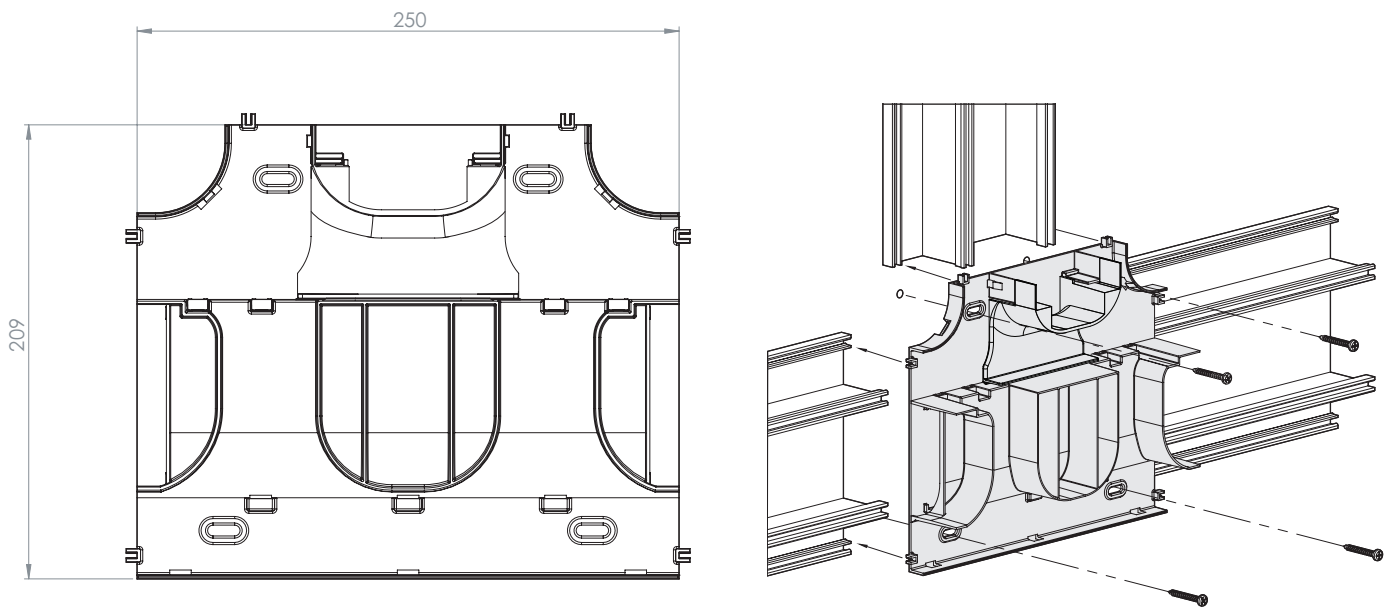

4. Using round head screws, fix backplate into position using all 4 fixing holes provided – applicable dimensions are provided on the diagram above. Align and fix the trunking base into position using the backplate guides. An expansion gap of 3mm should be provided between the backplate and trunking bases.

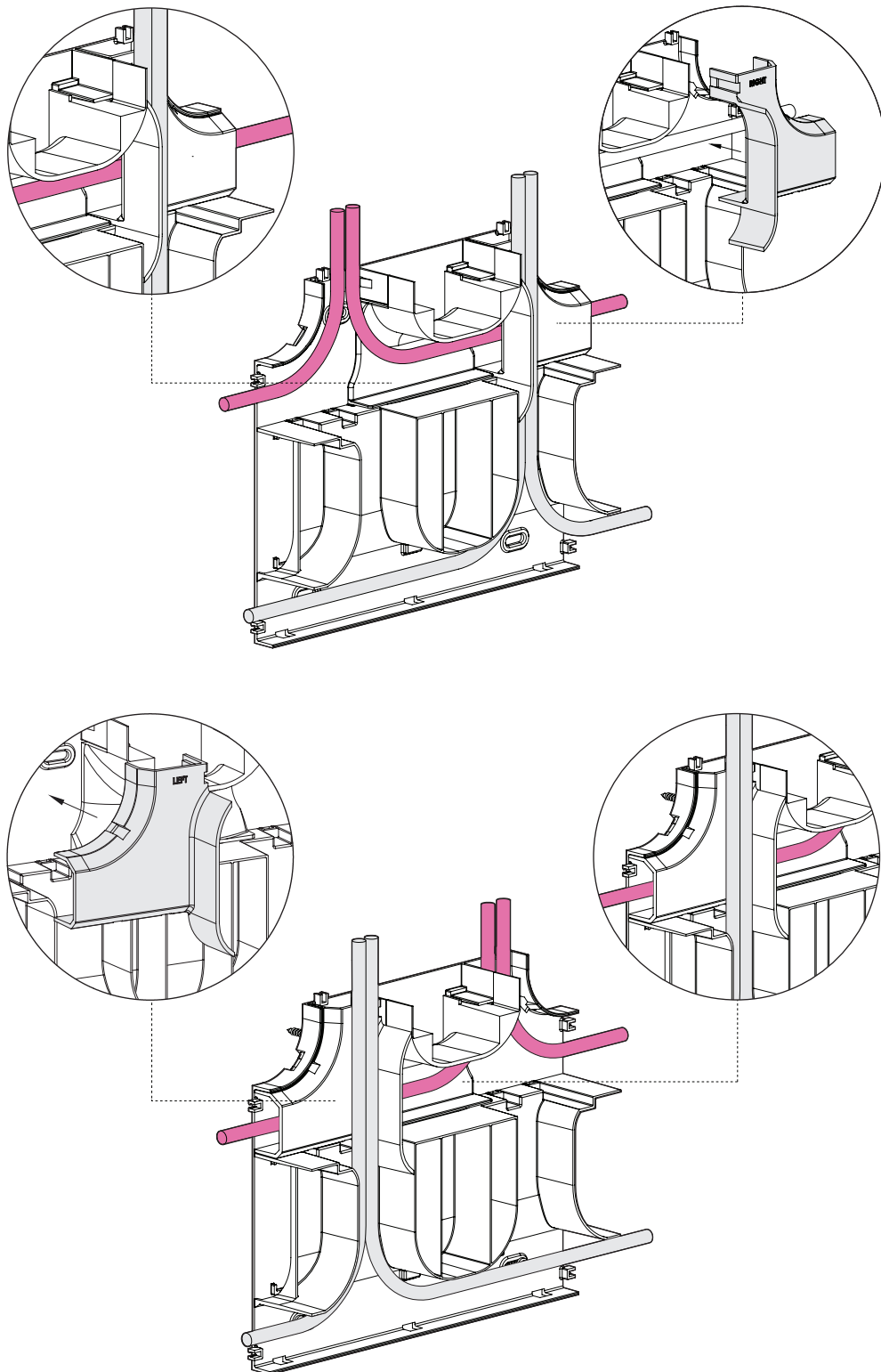

5. Configure the component as required by clipping in all applicable components and bridging pieces back into position on the backplate.

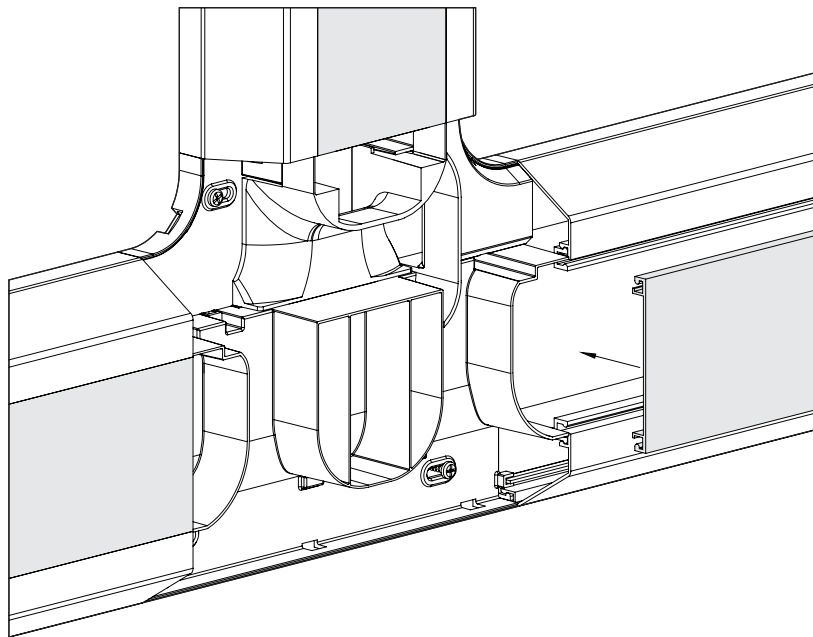
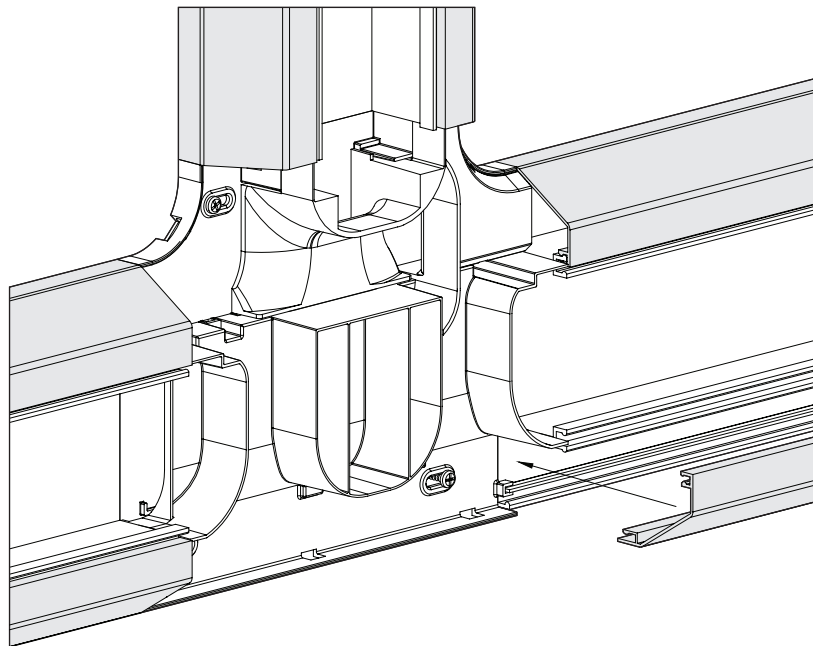

6. Once all cables are in position, all lids should be clipped onto the trunking base ensuring that their terminated ends are fully masked by the leading edge of the Flat Tee Cover (MERFT/COV) on final installation.

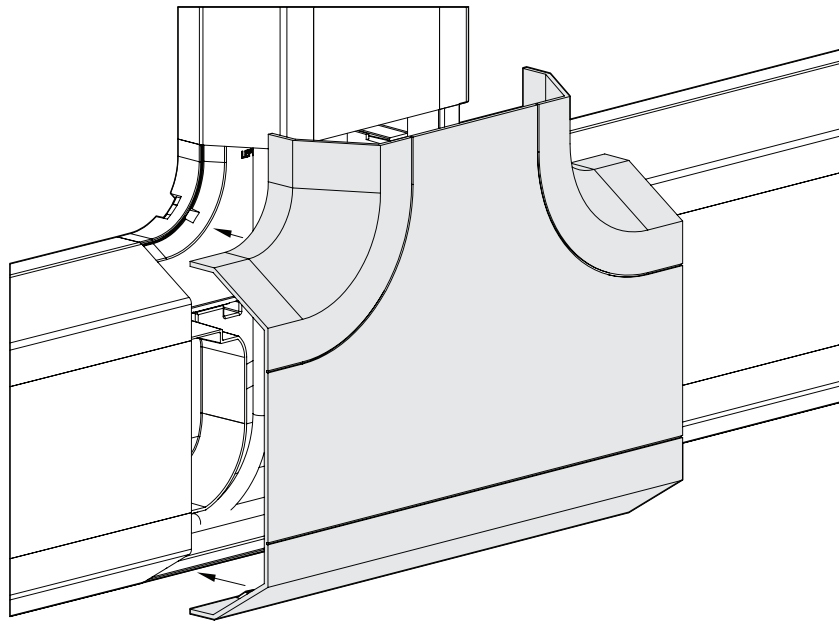

7. Locate the Flat Tee Cover (MERFT/COV) onto the backplate. It will clip into position as the mating features locate.

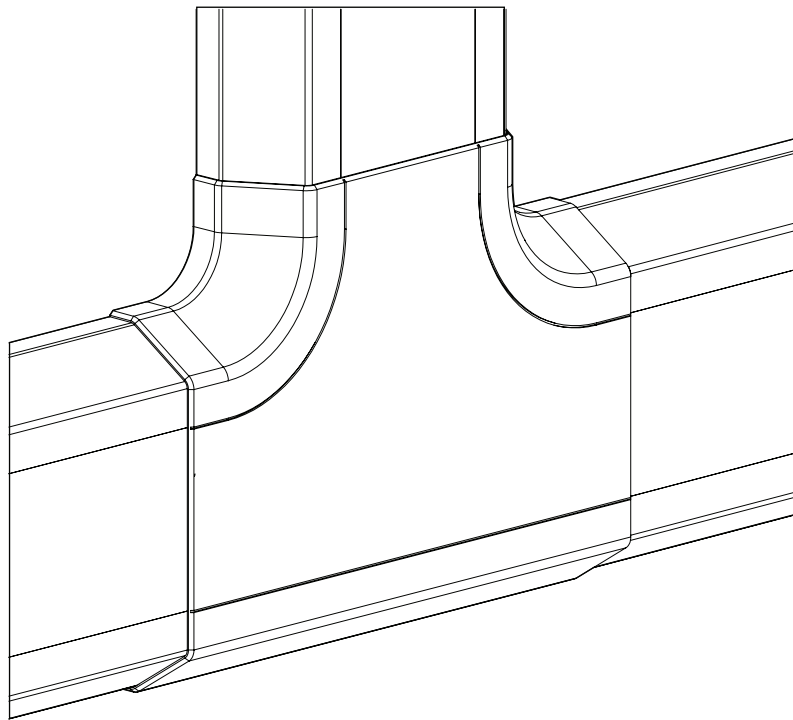

ADDITIONAL SECURITY OPTIONS

The cover unit can be further secured by mechanical means against unauthorised access by using Security Backplates (MERL/SBP) - available as an optional extra from your local Falcon stockist

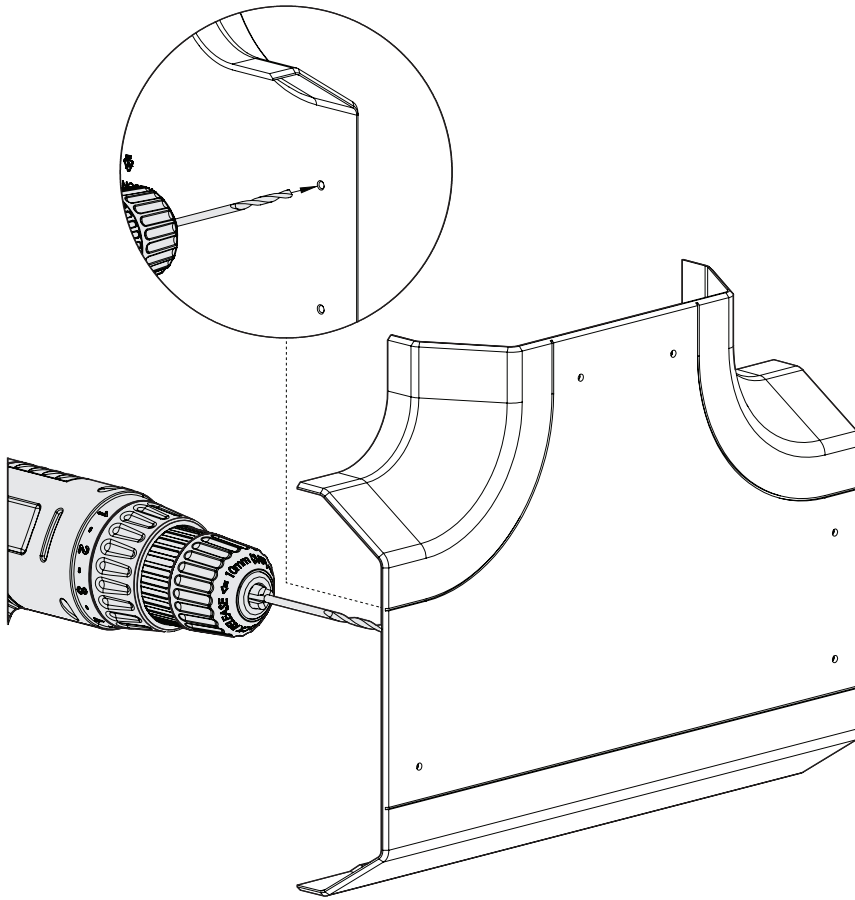

8. The Flat Tee Cover (MERFT/COV) has 6 (six) pilot hole guides on its underside – these should be drilled out using a 3mm drill as shown.

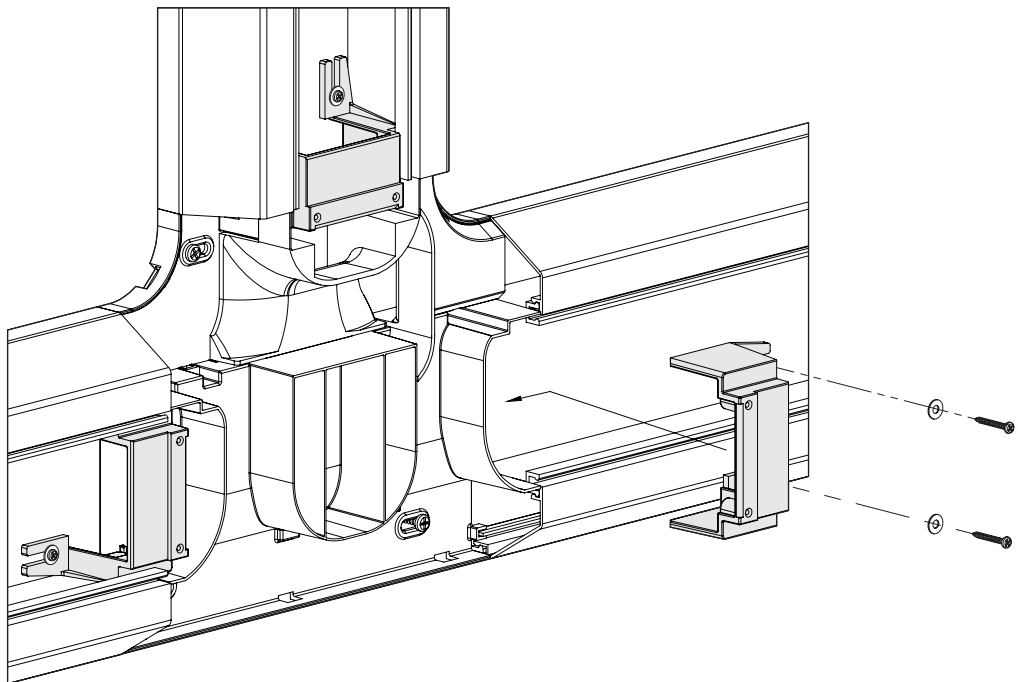

9. Locate the Security Backplates (MERL/SBP) into position within the centre compartments of both the main trunking run and the feeder branch and slide them into position until they hit the stops incorporated within the Centre Compartment Tunnel (MERFT/CCC) . Secure into position using plugs, No 8 round head screws and washers.

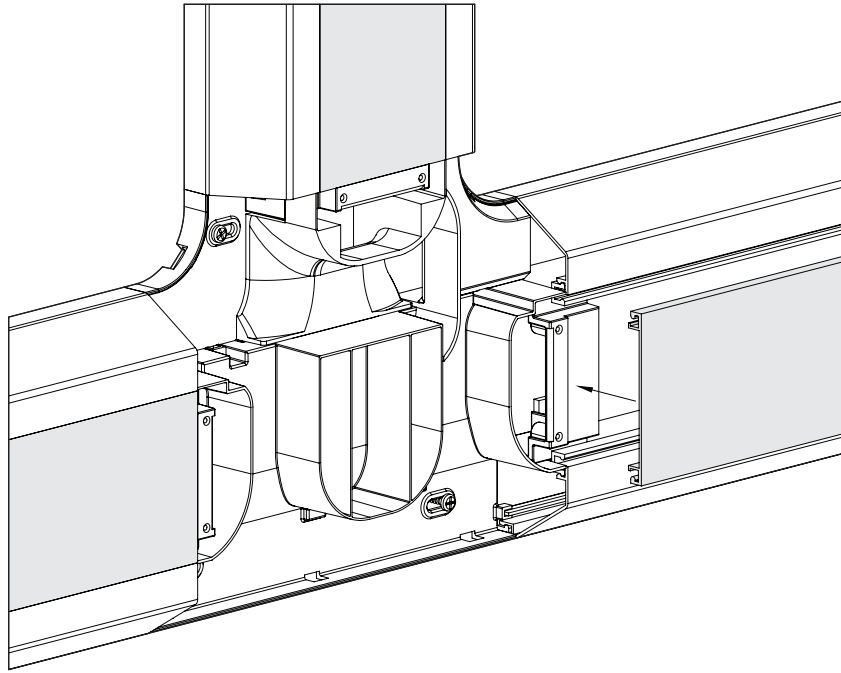

10. Replace the centre lids onto the trunking base ensuring that all their terminated ends are fully masked by the leading edge of the Flat Tee Cover (MERFT/COV) on final installation.

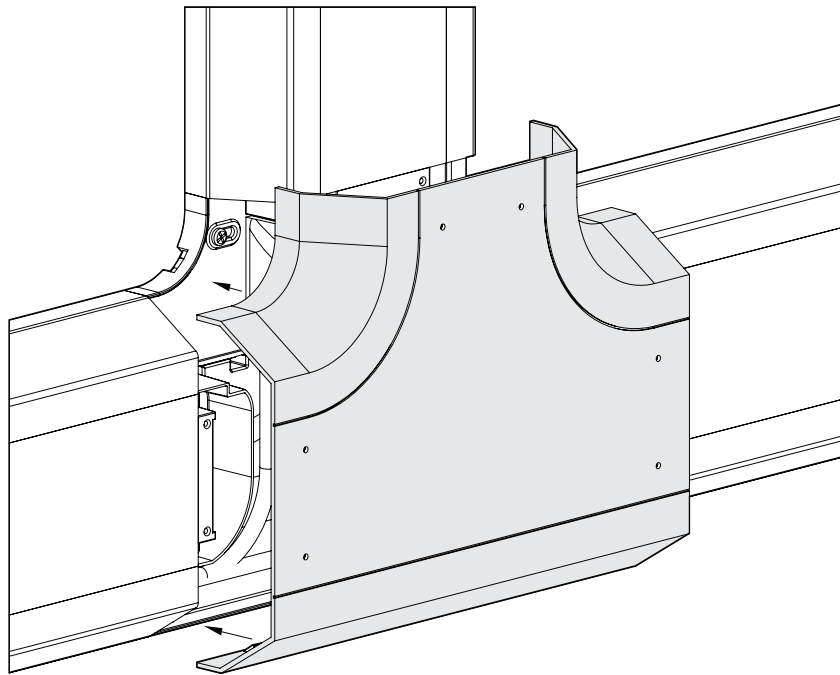

11. Locate the Flat Tee Cover onto the backplate. It will clip into position as the mating features locate.

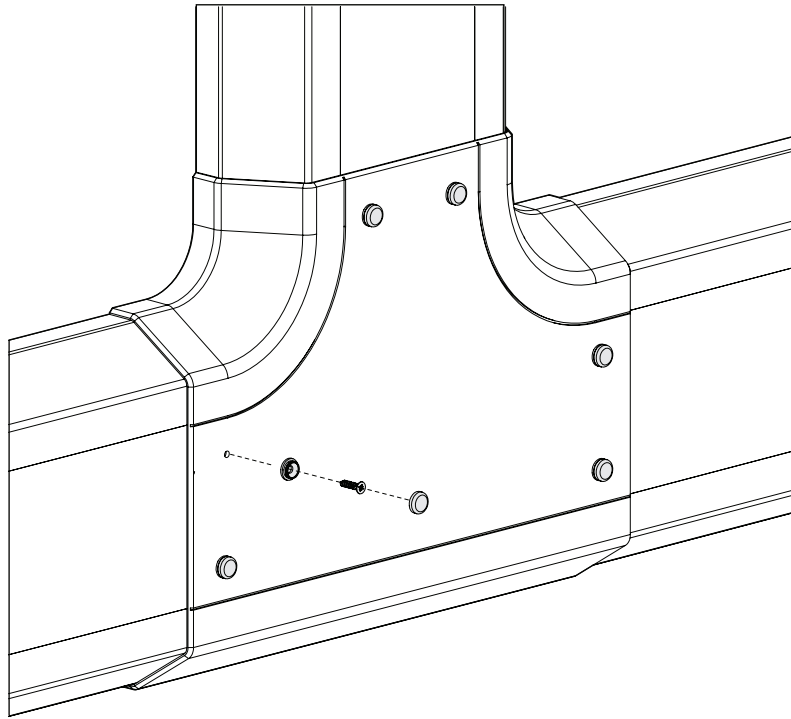

12. Using the screw seats and screws provided with the security backplates secure the front cover into position. Ensure the screws line up and locate within the columns of the security backplate. Do not overtighten.

13. Clip the caps provided onto the screw seat to mask the screw head.



FALCON TRUNKING
Systems Limited

Falcon Trunking Systems Limited, Butterworth Street, Littleborough, Lancashire OL15 8JS
(01706) 372929
sales@falcontrunking.co.uk